



**Solution Driven.**

## **Excellence in Cannabis Process Equipment, Technology & Customer Service**

Pope Scientific was founded in 1963 to provide a variety of apparatus to laboratories and pilot plants. The company quickly started doing business worldwide in a broad variety of industries with expanded offerings of production processing equipment including the Wiped-Film Molecular Distillation line and Toll Processing Services. Our first cannabinoid customer application goes back to 2003 for CBD concentration via wiped film stills; with the hemp actually being tossed out as waste from hemp seed oil processing. How times have changed!

Today, Pope sits at the forefront of cannabis processing technology with distillation, extraction, and isolation equipment being provided in the USA and internationally.

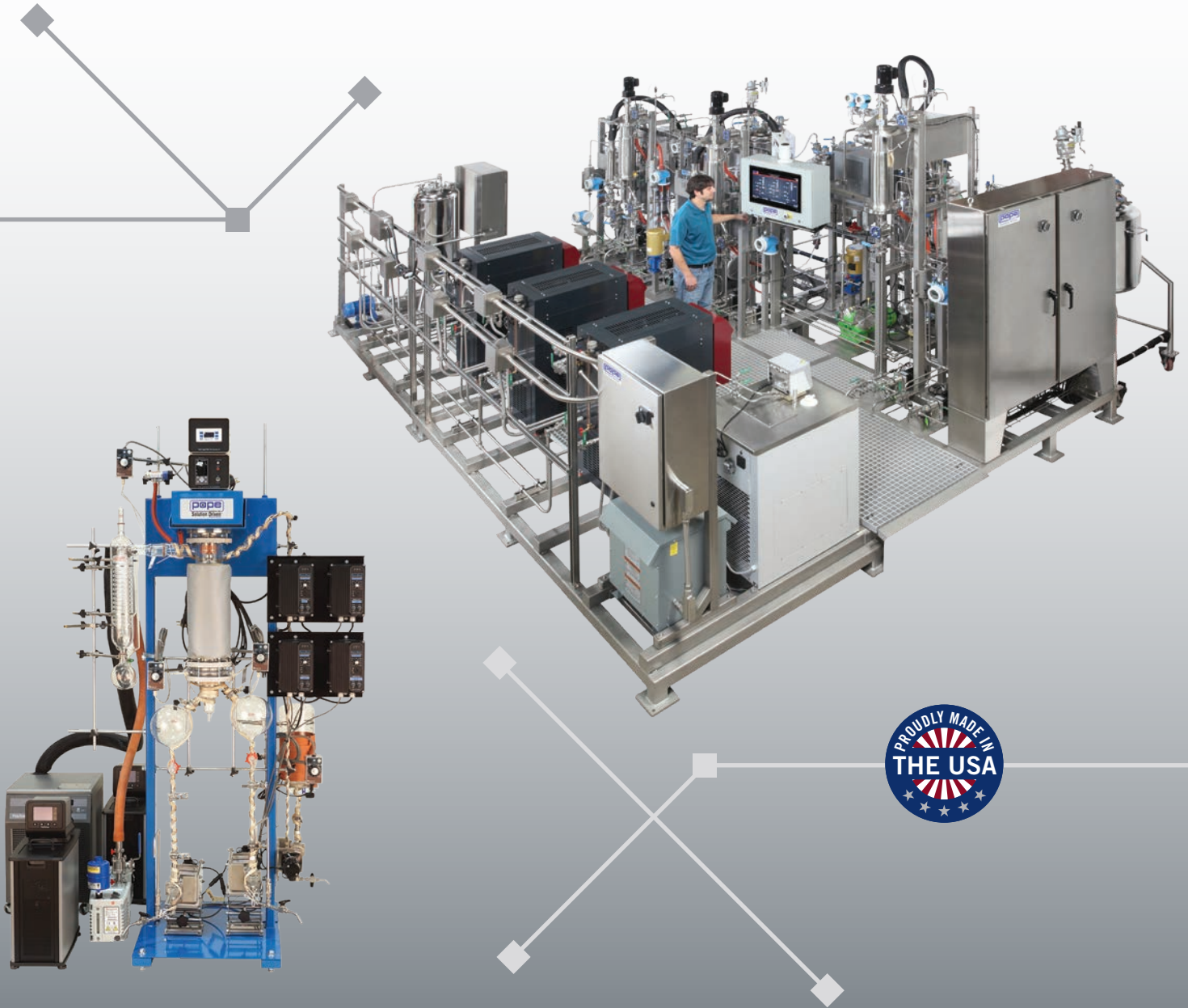

# Cannabinoid Purification Distillation Process

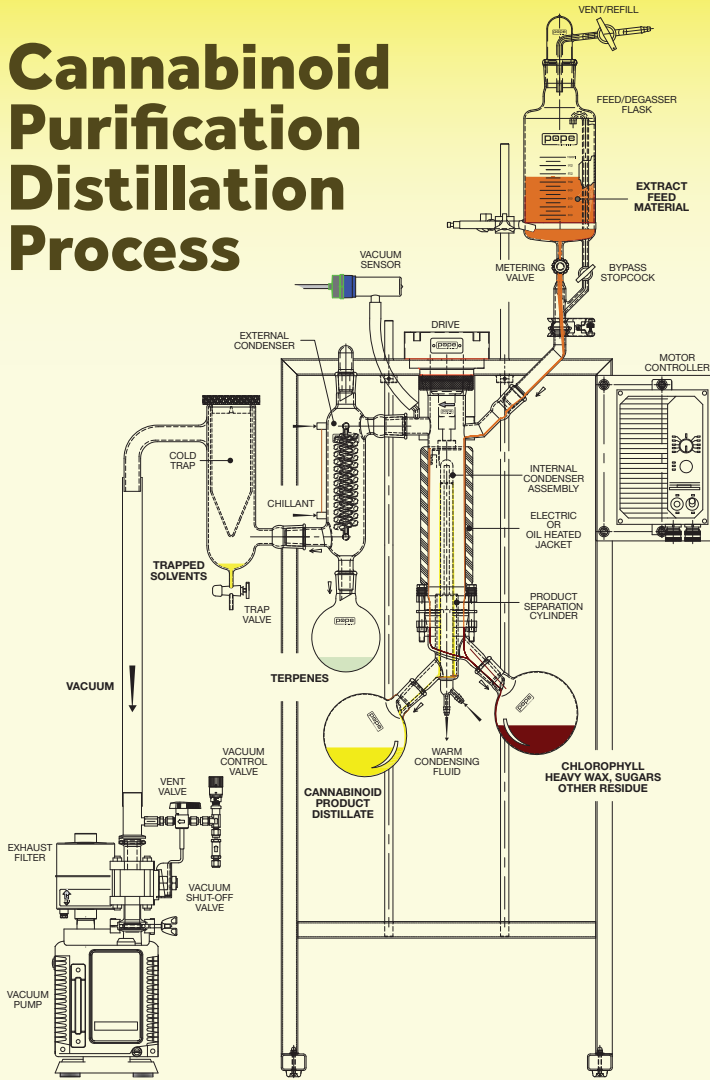

Diagram shows flow of feed material and the separation of component fractions.

## An Inside Look at How it Works & Why It's Superior

In the center of the body of our WFMS is an internal condenser providing a short path for vapor molecules traveling from the heated surface to the condenser surface.

**Short residence time**, (seconds), instead of hours of heating with batch distillation, results in not just greater purity, but significantly greater yield of available cannabinoid and lower degradation.

**Short distance, (short path)**, between evaporation and condensing surfaces, (see diagram below) is very important for efficiency at high vacuum levels. The common so-called "Short Path" batch stills are misnamed in the cannabis industry; there is nothing short path about their design at all!

Being a **continuous mode** system, as opposed to batch vessel apparatus, a Pope Wiped-Film Molecular Still (WFMS) can operate for extended periods of time with any quantity of feed material, small or large, and with the same consistent product composition for the entire run.

The WFMS is also **scalable**, so when much larger quantities of material (whether marijuana or hemp) need to be processed, larger version Pope stills can be utilized to accommodate the greater throughputs required.

## The Molecular Background

Wiped-Film Still technology takes advantage of the scientific fact that each chemical substance has a characteristic vapor pressure. It is this relative difference in vapor pressures which dictates how compounds can be separated into their constituent components.

And that in the most simplistic terms is what happens inside our stills, causing: the cannabinoids to be caught and collected by the internal condenser; the distillate to flow into one receiver flask; the residue material to flow into a different receiver flask; and the terpenes to be isolated by an external condenser and collected in a third receiver flask.

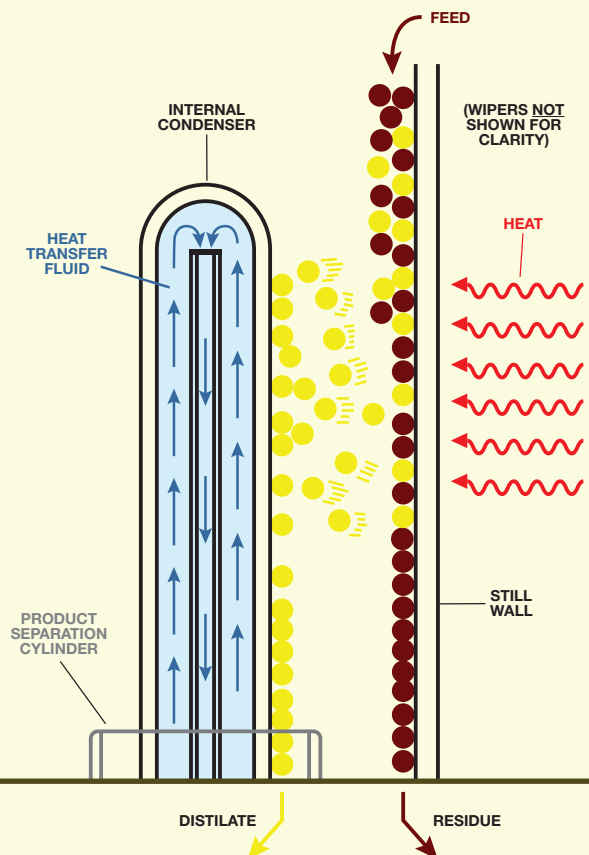
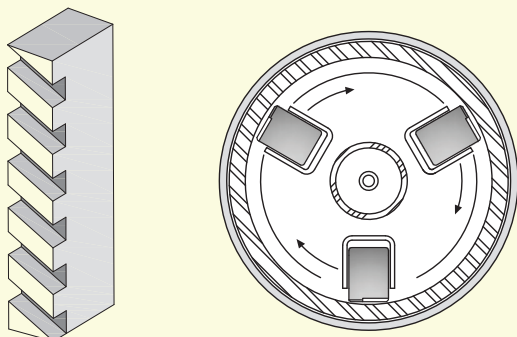

Pope's diagonally slotted wipers are designed to provide optimized **thin film** turbulence and to not only propel your material in a circular path around the inner cylindrical heater surface, but also downwards—resulting in shorter, more controllable residence time and minimizing product degradation. Rollers used by other manufacturers are not nearly as efficient or effective.

# Standard Models

*\*Feed Rate and Daily Throughput are dependent on process goals, feed stock and pre-processing steps.*



### 2" Still

- Feed Rate: 200-600g/hr
- Daily Throughput: 1000-1500g



### 4" Still w/Feed & Discharge Pumps (optional)

- Feed Rate: 600-2000g/hr
- Daily Throughput: 2000-5000g



### 6" Still w/Feed Pump (optional)

- Feed Rate: 1000-4000g/hr
- Daily Throughput: 4000-10,000g

## Available Options

- Diffusion Pump
- Stainless Steel Components
- Vacuum Control
- Paperless Data Recording
- Jacketed Still Bodies
- Feed & Discharge Pumps
- Feed Rate Control
- Other Customizations

*After extraction and winterization, THC is usually in the 60 to 70% purity range (CBD from hemp is even lower at 30 to 50% purity).*

*Starting with these feed percentages, you can certainly expect purity in the mid-80s+% after two passes and into the mid-90s+% using Pope distillation equipment.*

*Many of our customers have reported achieving much greater purity—low to mid-90s after two and close to 97% after three.*

# Multistage Continuous Systems

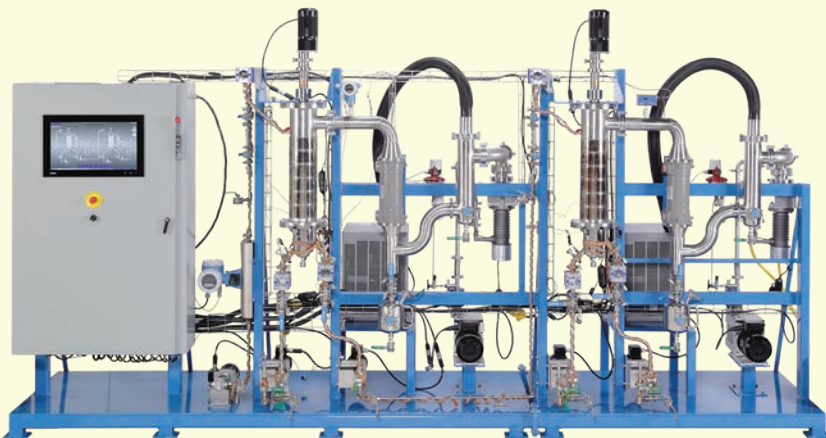

Our multistage, stainless steel, PLC-controlled, fully turnkey skid-mounted systems serve major cannabis production installations requiring capacities anywhere from 10 kg/hr up to 100 kg/hr. We are capable of engineering and manufacturing industrial production-sized stills as massive as you need.

Along with the increased size and continuous operation comes the same consistency of product composition over time and sustained quality.

# Industry Leading Solutions for Cannabis & Hemp Processing Excellence



## Wiped-Film Evaporators (WFE)

- Continuous Solvent Removal
- Better than Large Rotary Evaporators
- Scalable up to 200 L/hr



## Hybrid Wiped Film/Fractional Stills

- Terpene Distillation
- Solvent Recovery & Purification
- Specialty Batch and Continuous Applications



## Nutsche Filter-Dryers

- THCA/CBD Crystallization
- Jacketed for Precise Temperature Control
- Better than Buchner Funnels, ASME Certified



## Vessel/Reactor Systems

- Winterization & Ethanol Extraction Systems
- Cannabinoid Reaction Processing
- Custom Skid-mounted Liquid Handling Systems

*After distillation, isolation of certain cannabinoids by crystallization can be performed. A prime example is CBD production, where high purity and elimination of THC to less than 0.3% is required.*

*Pope's Nutsche Filter-Dryers have been used by many clients to provide >99.5% CBD crystal with very low to undetectable levels of THC.*



262.268.9300 • [popecannabisdistillation.com](http://popecannabisdistillation.com) •

351 N. Dekora Woods Blvd. Saukville, WI 53080, USA

For more information on Pope's chemical processing systems visit [popeinc.com](http://popeinc.com)

**pope**  
SCIENTIFIC INC.  
**Solution Driven.**